

Compact Series: Telephone Security and 6-way Video Panel

APPLICATION

Leviton's Compact Series: Telephone Security and 6-way Video Panel combines a Telephone Security Board and a 6-way 1 GHz Video Splitter in a dedicated plastic bracket for essential telephone and video distribution. It handles up to four telephone lines through to seven telephone connections with security interface and is suitable for phone, fax or modem. The Telephone Security and 6-way Video Panel features video output for up to six video connections.

STANDARDS COMPLIANCE

Meets all applicable standards: TIA/EIA-568-A and FCC Part 68 compliant.

PHYSICAL SPECIFICATIONS

Materials: Bracket:

ABS plastic, white.

1x7 Telephone Security Board:

Printed circuit board with seven bridged 4-pair 110-Type IDC connectors and security jack with switch.

6-way 1 GHz Video Splitter:

Die-cast housing and printed circuit board construction.

Dimensions: See second page.

6-way Splitter Specifications:

Insertion Loss: 10.0dB - 12.1dB
Return Loss: 6.5dB - 23.5dB
Isolation: 28.9dB - 37.5dB

DESIGN CONSIDERATIONS

- Fit easily into any Leviton Structured Media™ enclosure, or use as a stand-alone unit.
- Determine outlet locations and carefully plan cable routing to ensure the selected unit satisfies requirements.
- Install 75 Ohm termination caps on unused outputs of 6-way 1 GHz Video Splitter to reduce signal distortion or "ghosting".
- Use Video Amplifier for increased signal strength.
- Supports security systems via RJ-45 style interface with on/off (bypass) switch.

See ELECTRONIC FILES for CAD files (.DXF, .DWG, MS-DOS.EPS) on disk



WARRANTY INFORMATION

- Two-year limited product warranty.

For ELECTRONIC Typical Specs see (.TXT) file on disk.

TYPICAL SPECIFICATION

The Compact Series Telephone Security and 6-way Video Panel shall meet all applicable standards: TIA/EIA-568-A and FCC Part 68 compliant. The unit shall distribute up to four telephone lines through to seven telephone connections with a security interface, making it suitable for phone, fax or modem. The unit also features video output for up to six video connections. The unit shall include a plastic mounting bracket, Telephone Security, and 6-way 1 GHz Video Splitter. It shall fit into any Leviton Structured Media enclosure, or used as a stand-alone unit. A two-year limited product warranty shall be provided by the manufacturer.



For Technical Support Call 1-425-485-4288; in USA call 1-800-824-3005
Spec sheets and updates are also available at www.levitonvoicedata.com.

2222 - 222nd St. SE • Bothell, WA 98021 USA
Tel: 1-800-722-2082 / 1-425-485-4288 • Fax: 1-425-483-5270 • Int'l Fax: 1-425-485-9170 • GSA Schedule Available



Compact Series: Telephone Security and 6-way Video Panel

Part Number
47603-TSV

.....

DIMENSIONAL LINE ART

See ELECTRONIC FILES for CAD images
(.DXF, .DWG, MS-DOS.EPS)

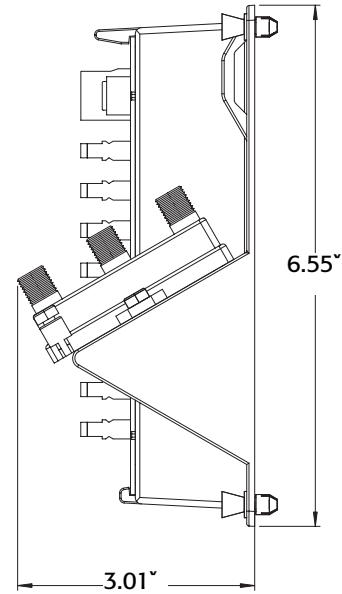
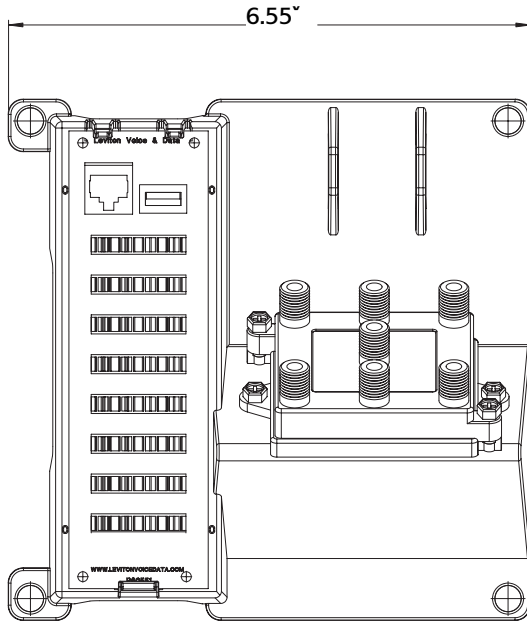

PART NUMBERS

Description	Part No.
Compact Series: Telephone and 6-way Video Panel	47603-TSV



For Technical Support 1-425-485-4288; in USA call 1-800-824-3005.
Spec sheets and updates are also available at www.levitonvoicedata.com.



2222 - 222nd St. SE • Bothell, WA 98021 USA • Tel: 1-800-722-2082 / 1-425-485-4288 • Fax: 1-425-483-5270 • Int'l Fax: 1-425-485-9170 • GSA Schedule Available